

REFERENCE	BT_2014_FR1.6_1_UK
DATE	16 April 2014
SUBJECT	New exhaust 2014, brake caliper piston springs removing, wheel bearing grease, camera with inboard battery fitting, radiator grids
PART	Exhaust, brake calipers, wheel bearing, camera, radiator nets

## 1. New exhaust 2014

In order to respect Nordic and NEC Junior Formula Renault 1.6 championship noise regulations, a new exhaust has been designed to reduce significantly the exhaust noise level.

This new exhaust will be available under the following reference

[Exhaust Muffler and Pipe V2014 ref: G04-06C002V3 \(n°2\)](#)

The new 2014 exhaust needs to be assembled on the car using the new parts listed below specifically designed for this application:

Rep	Part reference	Part name	Qty	Comment
2	G04-06C002V3	Exhaust Muffler and Pipe V2014	1	
4	G04-06C004V2	Muffler Support V2014	1	
8	G04-06C008V1	Catalyser Collar	1	<b>For FR1.6 Nordic customers only</b>
9	G04-06V009V1	Muffler Strap V2014	1	

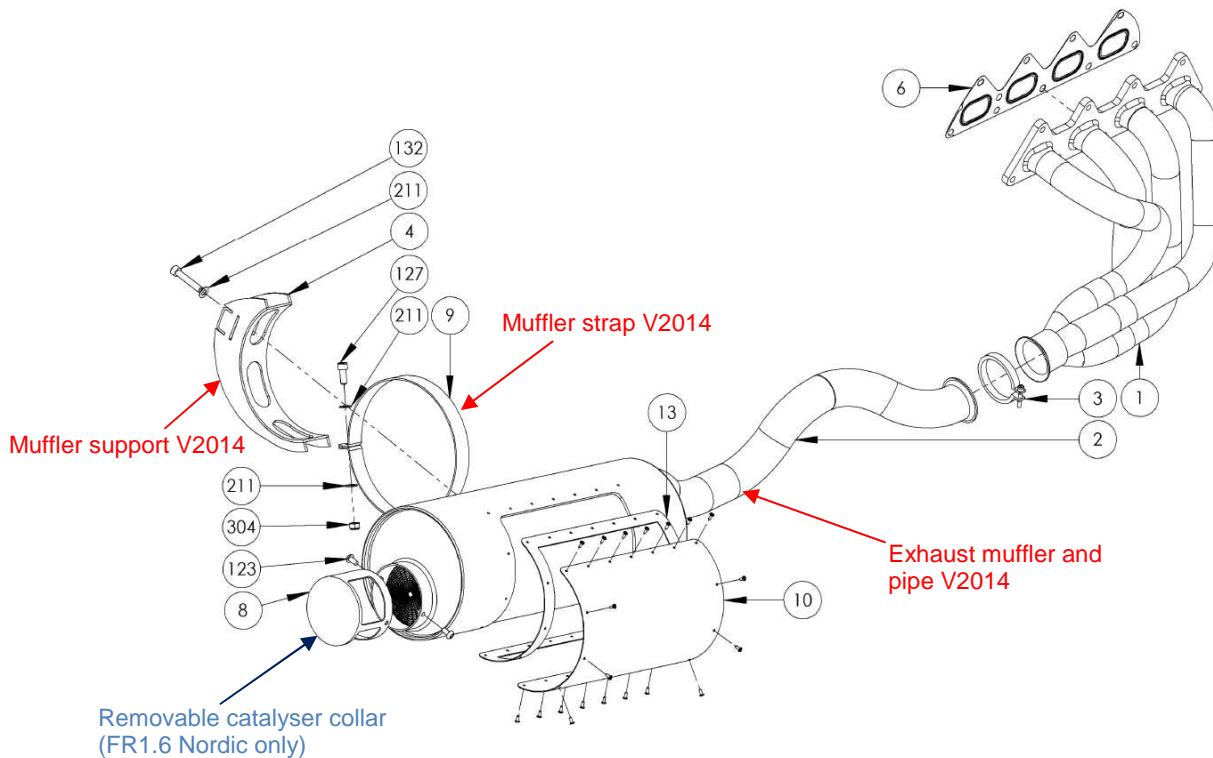

Rep.	Reference	Part Name	Qty
	G04-06C000	<b>Exhaust 2014</b>	
1	G04-06C001V1	Exhaust Manifold	1
2	G04-06C002V3	Exhaust Muffler and Pipe V2014	1
3	G04-06C003V1	Exhaust Pipe Clamp	1
4	G04-06C004V2	Muffler Support V2014	1
6	G04-06C006V1	Exhaust Gasket	1
8	G04-06C008V1	Catalyser Collar	1
9	G04-06V009V1	Muffler Strap	1
10	G04-06C010V1	Locking Plate	1
13	G04-06C013V1	Muffler Seal	1
123	G04-21A023V1	BHC M6 x 12	2
127	G04-21A027V1	CHC M8 x 20	1
132	G04-21A032V1	CHC M8 x 45	1
211	G04-21B011V1	Flat Washer Ø8 x 16	3
304	G04-21C004V1	Nylstop M8	1

**Note:**

For cars entering the FR1.6 Nordic championship, the use of a specific removable catalyser collar (n°8) is compulsory. This collar can be oriented in two positions to exit the exhaust flow either on the right or on the left side.

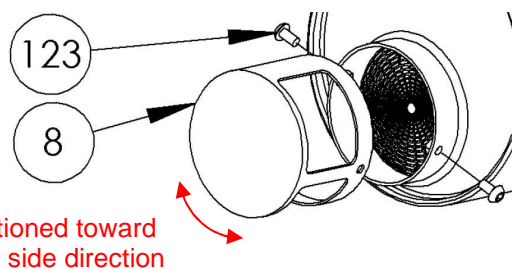

Exit can be positioned toward right or left hand side direction

This catalyser collar (ref: G04-06C008V1/ n°8) will be available directly through the FR1.6 Nordic promoter.

**2. Caliper piston springs removing**

It is now allowed to remove the caliper piston springs following the procedure below:

- Remove the caliper bridge pipe.

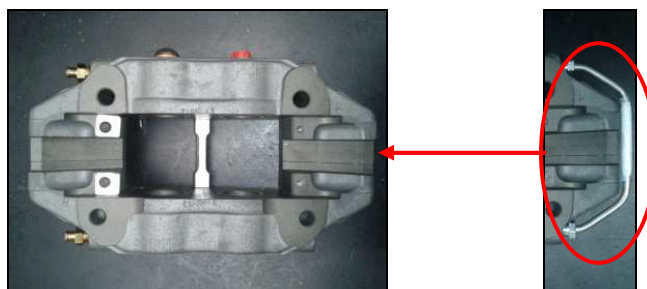

- Place a block of wood (or similar) in the middle of the caliper.

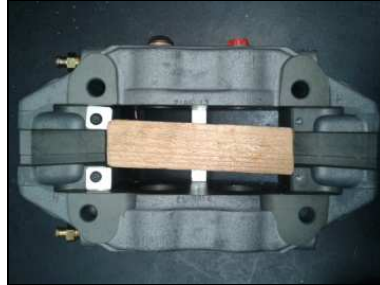

- Place an air blow gun in the hole of the caliper pipe and pressurize to push the pistons out.

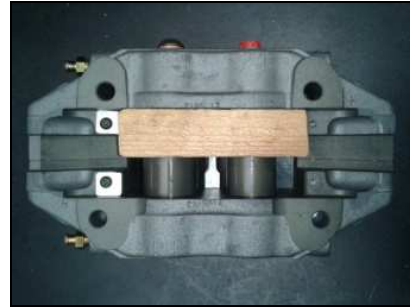
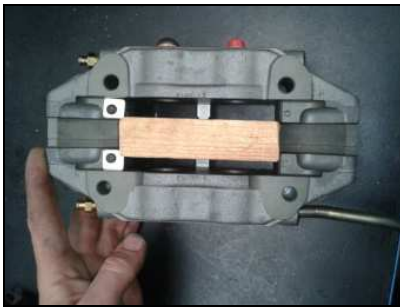

- Remove the block of wood and remove the springs



- Put the pistons back in place.
- Repeat these steps for the other side of the caliper.
- Put the caliper pipe back in place.

### 3. Wheel bearing grease

Wheel bearing grease is now free.

### 4. Camera with inboard battery fitting

Any camera with inboard battery (like GoPro®) fitted on the car must have its casing safely secured to the car using a steel wire (or similar) as shown below:



### 5. Radiator nets

It's allowed to fit radiator nets onto the car following these points below:

- Radiator nets must be fitted inside the sidepod. Nets location is ruled at 5cm behind the sidepod inlet section as shown below:



- Shape and dimensions of the nets are free